



Why use hydraulic bolt tensioners ?

Using the hydraulic bolt tensioner:

The RAPID-TORC bolt tensioner is an annular hydraulic jack which is placed around the studbolt and stretches it axially using oil pressure. When the required stress level is reached in the studbolt, the nut is tightened by hand. The oil pressure is then released and the studbolt retains the preload stress. This is done without any frictional torque, and the studbolt tension is therefore controlled very accurately. The same tool can be used to disassemble the bolt.

Operation of the RAPID-TORC bolt tensioner is very easy and quick. For studs of large diameters, it is even incomparably easier and safer than using any kind of wrench.

- ➡ No heating
- ➡ No shocks

- ➡ Accurate
- ➡ Repeatable

- ➡ Quick
- ➡ Lightweight
- ➡ No injuries





Why use hydraulic bolt tensioners ?

How does it work ?

Step 1 : Screw the nut on the studbolt by hand. Then place the hydraulic tensioner round the stud

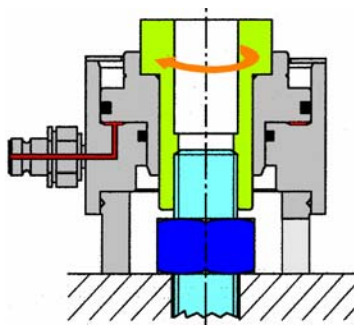
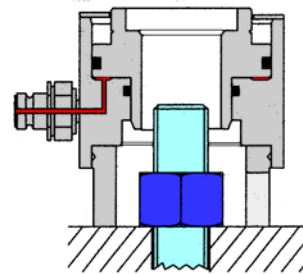

Step 2 : Screw the puller (traction/ reaction nut) on the tip of the studbolt.

Step 3 : apply the hydraulic pressure into the tensioner (up to 1500 bar). The tensioner pulls and extends the stud vertically. The oil pressure gives a good indication of the tension stress in the studbolt.

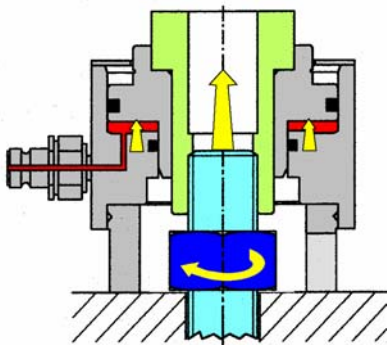
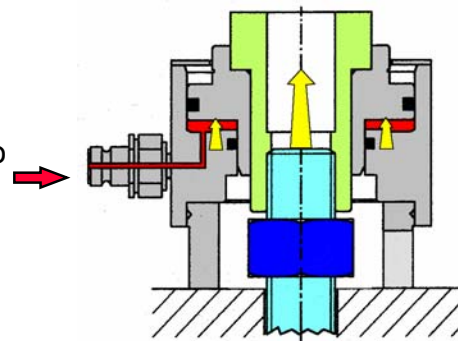

Step 4 : While keeping the tensioner under pressure, screw the nut by hand until it comes in contact with the flange. Then release the oil pressure in the tensioner. The nut retains the tension in the stud bolt. The puller and the tensioner may be removed.



Why use hydraulic bolt tensioners ?

The benefits

The tension load in the stud is accurately known.

The residual tension load in the studbolt is very close to the maximum load applied by the hydraulic pressure. This is simply measured with a manometer.

It is possible to preload a stud bolt to a higher stress value.

Mechanical engineering teaches that high bolts preload provides assemblies with a better behaviour with respect to dynamic loads, fatigue, high temperature variations and thermal shocks. Because hydraulic tightening is so accurate, it is possible to preload the stud much nearer to its elastic limit than with conventional wrench tightening.

All the studbolts of a flange or assembly can be simultaneously tightened.

By providing each stud with a tensioner or 50 % of them, and connecting all the tensioners to the same oil pressure source, all the studbolts are tightened simultaneously, and exactly to the same load value. This guarantees a uniform load on the flanges, and an even compression of the seal. Better tightness, longer lifetime, better resistance to fatigue and to high temperature variations are the benefits of this method.

